

SPECIFICATION FOR APPROVAL

CUSTOMER: _____

PART NO: _____

DESCRIPTION: FGB2012-300-NP

SUBMIT NO: _____

QUANTITY: _____ **PCS**

DATE: _____

方瑞达电子（香港）有限公司		
FONRITA ELECTRONICS (H.K) CO., LTD.		
MADE	CHECKED	APPROVED
张达	黎敏	邓锋

贵 公 司 承 认 栏		
APPROVED BY MANGEMNT		
MADE	CHECKED	APPROVED



方瑞达电子（香港）有限公司

FONRITA ELECTRONICS (H.K) CO., LTD.

地址：广东省深圳市龙华新区大浪鹤山路口光浩工业园F栋4楼

TEL:0755-26617190

FAX:0755-26162625

CUSTOMER :		PART NO.	
SPECIFICATIONS		DATE	
PART NAME	DATA SHEET	SPEC(TYPE)	FGB2012-300-NP

TEST INSTRUMENT

- 1.HP4291A RF IMPEDANCE / MATERIAL ANALYZER FOR Z
- 2.DIGITAL MULTIMETER SC-7401 FOR RDC
- 3.Rated Current (mA)Max. : 300(Thermometer&HP6632A or HP6632A or HP42841A or CH301A)

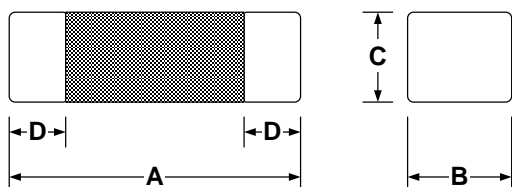

● **PRODUT IDENTIFICATION:**

FGB 20 12 300 - NP
 1 2 3 4 5

- 1.PRONDUCT SYMBOL 2.OUT SIDE DIA:mm
- 3.BODY WIDE :mm 4.Normal impedance
- 5.Meet ROHS Regulations of Prohibiped 6 Poisonous Materials

ELECTRICAL CHARACTERISTICS				DIMENSION			
ITEM	Z(Ω)	RDC(Ω)	IDC(mA)	A	B	C	D
SPEC.	100MHz	Max.	Max.	m/m	m/m	m/m	m/m
	30±25%	0.008	6000	2.0±0.2	1.25±0.2	0.9±0.2	0.5±0.3
1							
2							
3							
4							
5							
6							
7							
8							
9							
10							
\bar{X}							
R							
TEST CONDITION		TEMP:	25°C		HUMIDITY:	50%	
DRAWN BY			CHECKED BY			APPROVED BY	
张达			黎敏			邓锋	



CUSTOMER :		PART NO.	
SPECIFICATIONS		DATE	
PART NAME	MATERIAL LIST	SPEC(TYPE)	FGB2012-300-NP

■ Rating:

Operating Temperature: -55°C~125°C

Storage Temperature: -40°C~85°C

■ Marking:

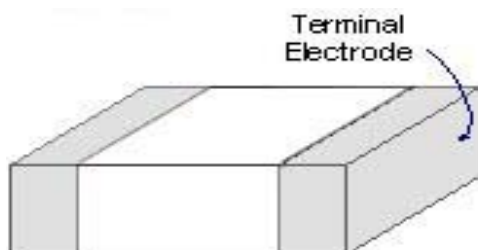

■ Specification

Impedance-Frequency Characteristics

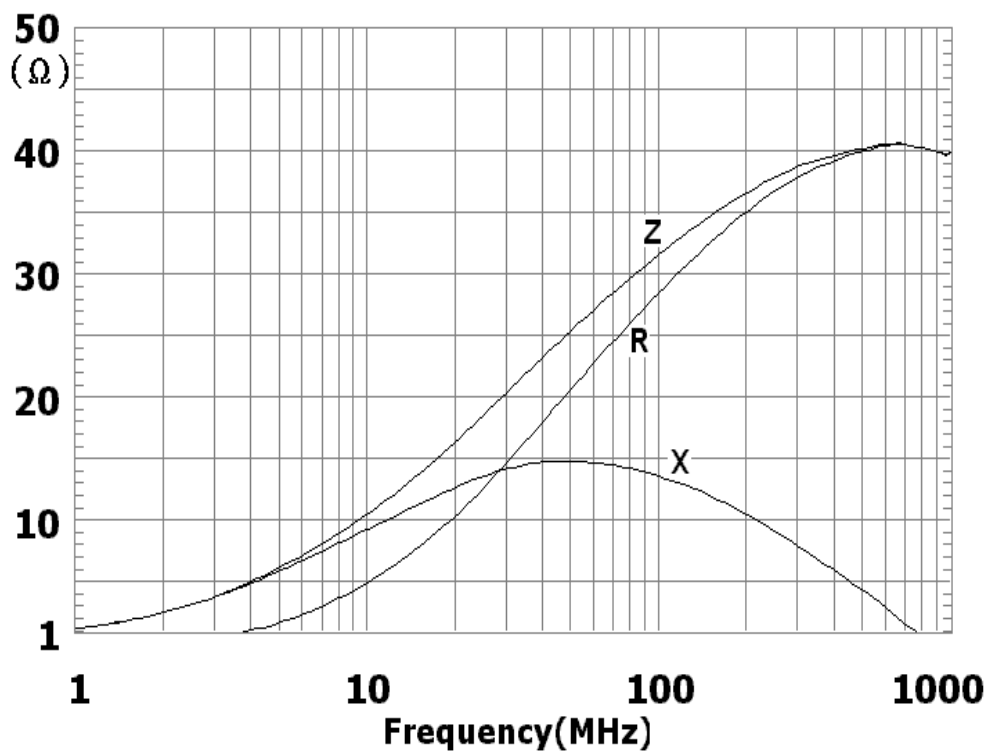

方瑞达电子(香港)有限公司

FONRITA ELECTRONICS (H.K) CO.,LTD.

CUSTOMER :		PART NO.	
SPECIFICATIONS		DATE	
PART NAME	Series Specification	SPEC(TYPE)	FGB2012-300-NP

■ Construction:

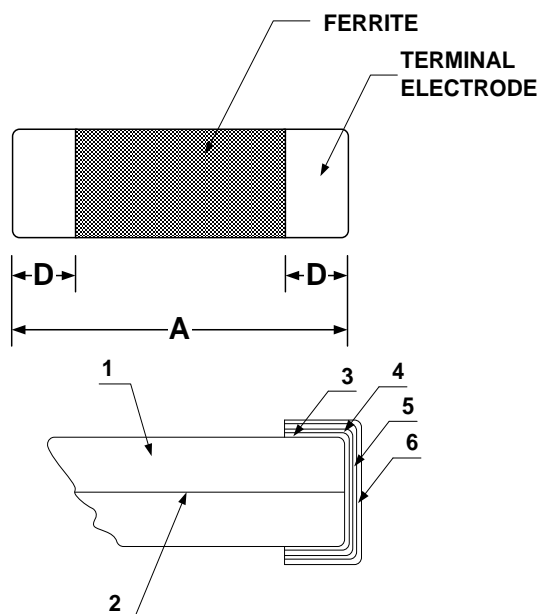

NO	PART	MATERLAL
1	Ferrite Substance	NiO-CuO-ZnO-Ferrite
2	Silver electrode	Ag
3	Silver electrode	Ag
4	Cu plating	Cu
5	Ni plating	Ni
6	Sn plating	Sn

■ Standard Testing Condition

	Unless otherwise specified	In case of doubt
Temperature	Ordinary Temperature(15 to 35℃)	20±2℃
Humidity	Ordinary Humidity(25 to 85% RH)	60 to 70 % RH



CUSTOMER :		PART NO.	
SPECIFICATIONS		DATE	
PART NAME	MATERIAL LIST	SPEC(TYPE)	FGB2012-300-NP

■ Reliability of Chip Beads (FGB SERIES)

1. Mechanical Performance

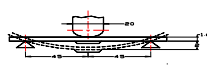
NO	Item	Specification	Test Method
1	Flexure Strength	Appearance :No damage L change :within±10% Q change :within±30%	Test device shall be soldered on the substrate Substrate Dimension:100*40*1.6mm Deflection:2.0mm Keeping Time:30sec For 100505,substratedimension is 100*40*0.8mm 
2	Vibration		Test device shall be soldered on the substrate Oscillation Frequency : 10 to 55to 10Hz for Amplitude : 1.5mm Time : 2hrs for each axis (X , Y & Z), TOTAL
3	Resistance to Soldering Heat	Appearance :No damage More than 75% of the terminal Electrode should be covered with solder. Impedance: with in ±15% of initial value. Q: within±30%of initial value	Pre-heating: 150°C , 1min Solder Composition: Sn/3.0Ag/0.5Cu Solder Temperature:260±5°C Immersion Time:10±1SEC Measured after exposure in the room condition for 24hrs
4	Solderability	The electrodes shall be at least 90% covered with new solder coating	Pre-heating : 150°C,1min Solder Composition :Sn / Ag =96.5/3.5 Solder Temperature :245±5°C Immersion Time :4±1sec



CUSTOMER :		PART NO.	
SPECIFICATIONS		DATE	
PART NAME	MATERIAL LIST	SPEC(TYPE)	FGB2012-300-NP

■ Reliability of Chip Beads (FGB SERIES)
Environmental Performance

NO	Item	Specification	Test Method		
1	Temperature Cycle	Appearance : No damage	Once cycle:		
		L change : within±10%	Step	Temperature (°C)	Time(min)
		Q change : within±30%	1	-25±3	30
			2	25±2	3
			3	85±3	30
			4	25±2	3
		Total:100chcles Measured after exposure in the room condition for 24hrs			
2	Humidity Resistance		Temperature :40±2°C Relative Humidity : 90~95% Time : 1000hrs Measured after exposure in the room condition for 24hrs		
3	Heat Temperature Resistance		Temperature :85±3°C Relative Humidity :20% Applied Current: Rated Current Time :1000hrs Measured after exposure in the room condition for 24hrs		
4	Low Temperature Resistance		Temperature :-25±3°C Relative Humidity:0% Time : 1000hrs Measured after exposure in the room condition for 24hrs		



CUSTOMER :		PART NO.	
SPECIFICATIONS		DATE	
PART NAME	CARRIER & REEL	SPEC(TYPE)	FGB2012-300-NP

■ **PACKAGING**

Packaging – Cover tape

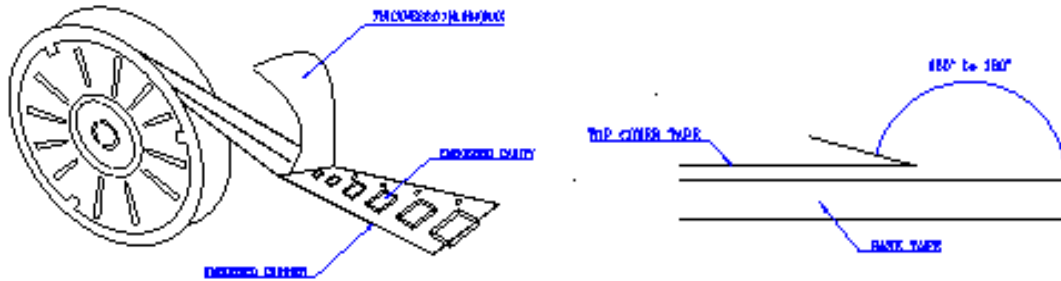

Packaging Quantity

TYPE	BULK	PCS/REEL
FGB-2012	✓	4000

■ **REEL DIMENSION :m/m**

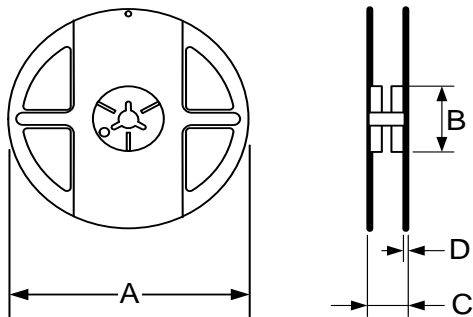

TYPE	A	B	C
FGB-2012	178	60	12



方瑞达电子(香港)有限公司

FONRITA ELECTRONICS (H.K) CO.,LTD.